

Modular Cooking Range Line EVO900 Two Wells Electric Fryer 18 liter

ITEM # _____

MODEL # _____

NAME # _____

SIS # _____

AIA # _____



Modular Cooking Range Line

EVO900 Two Wells Electric Fryer 18 liter

392095 (Z9FREH2HF0) 18+18-lt electric fryer with 2 wells (internal heating elements) and 4 half size basket - free standing

392179 (Z9FREH2HFN) 18+18-lt electric fryer with 2 wells (internal heating elements) and 4 half size baskets - free standing

Short Form Specification

Item No. _____

High efficiency tilting incoloy armoured heating elements (33kW) placed inside the wells. Deep drawn wells. Oil drains through a tap into a container positioned under the wells. Height adjustable feet in stainless steel. Exterior panels in stainless steel. Worktop in 20/10, stainless steel. Right-angled side edges eliminate gaps and possible dirt traps between units.

Main Features

- Interior of wells with seamlessly laser-welded corners for ease of cleaning.
- Swivelling incoloy armoured heating elements located inside the well can be lifted up for easier cleaning.
- Thermostatic regulation of oil temperature up to a maximum of 185 °C.
- Overheat protection thermostat as standard on all units.
- Oil drains through a tap into a drainage container positioned under the well.
- All major compartments located in front of unit for ease of maintenance.
- IPX5 water resistance certification.
- The special design of the control knob system guarantees against water infiltration.
- Unit delivered with four 50 mm legs in stainless steel as standard (all round Stainless steel kick plates as option).
- Supplied as standard with 4 half size baskets and 1 right and left side doors for cupboard.

Construction

- All exterior panels in Stainless Steel with Scotch Brite finishing.
- Model has right-angled side edges to allow flush fitting joints between units, eliminating gaps and possible dirt traps.
- Unit is 900mm deep to give a larger working surface area.

APPROVAL: _____

Included Accessories

- 2 of Door for open base cupboard PNC 206342
- 2 of 2 half size baskets for 18/23lt well fryers PNC 927223

Optional Accessories

- Junction sealing kit PNC 206086
- 4 wheels, 2 swivelling with brake (EVO700/900). It is mandatory to install with base supports for feet/wheels. PNC 206135
- Flanged feet kit PNC 206136
- Frontal kicking strip for concrete installation, 800 mm PNC 206148
- Frontal kicking strip for concrete installation, 1000 mm PNC 206150
- Frontal kicking strip for concrete installation, 1200 mm PNC 206151
- Frontal kicking strip for concrete installation, 1600 mm PNC 206152
- Pair of side kicking strips (concrete installation) PNC 206157
- Side handrail for right/left hand PNC 206165
- Frontal handrail 400 mm PNC 206166
- Frontal handrail 800 mm PNC 206167
- Frontal kicking strip, 800 mm PNC 206176
- Frontal kicking strip, 1000 mm PNC 206177
- Frontal kicking strip, 1200 mm PNC 206178
- Frontal kicking strip, 1600 mm PNC 206179
- Pair of side kicking strips PNC 206180
- 2 panels for service duct (single installation) PNC 206181
- Large handrail (portioning shelf) 400 mm PNC 206185
- Large handrail (portioning shelf) 800 mm PNC 206186
- Frontal handrail 1200 mm PNC 206191
- Frontal handrail 1600 mm PNC 206192
- 2 panels for service duct (back to back installation) PNC 206202
- 4 feet for concrete installation (not for 900 line freestanding grill) PNC 206210
- Water column with swivel arm (water column extension not included) (only for 392179) PNC 206289
- Chimney upstand, 800 mm PNC 206304
- 2 side covering panels, height 700 mm, depth 900 mm PNC 206335
- Door for open base cupboard PNC 206342
- Filter for fryer oil collection basin for 15lt, 18lt, 23lt free standing fryers PNC 206359
- Base support for feet or wheels - 800mm (EVO700/900) PNC 206367
- 2 half baskets for 18/23lt fryers with front hook PNC 927200
- 1 full basket for 18/23lt fryers with front hook PNC 927201
- 2 half size baskets for 18/23lt well fryers PNC 927223
- 1 full size basket for 18/23lt well fryers PNC 927226

- Unclogging rod for 23lt fryers drainage pipe PNC 927227

Front

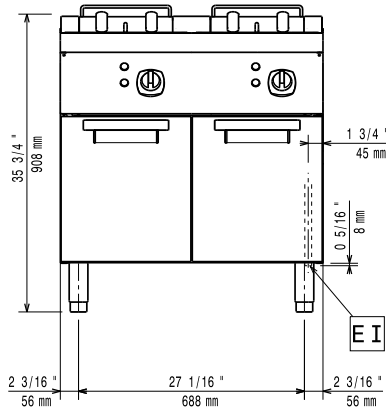

Top

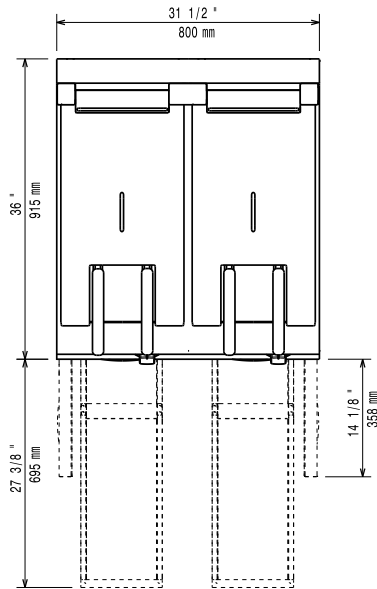

EI = Electrical connection
EQ = Equipotential screw

Side

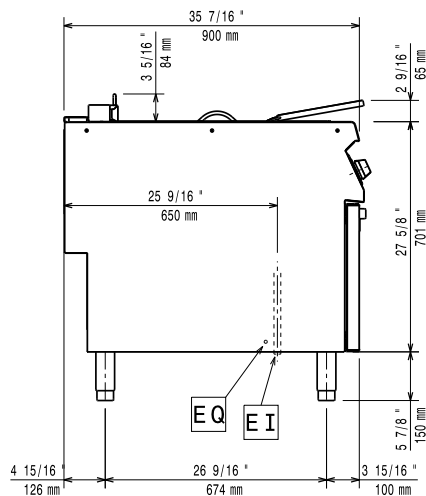

Electric

Supply voltage:

392095 (Z9FREH2HF0)	400 V/3N ph/50/60 Hz
392179 (Z9FREH2HFN)	230 V/3 ph/50/60 Hz

Total Watts:

33 kW

Key Information:

Usable well dimensions (width):	340 mm
Usable well dimensions (height):	290 mm
Usable well dimensions (depth):	400 mm
Well capacity:	18 lt MIN; 20 lt MAX
Thermostat Range:	105 °C MIN; 185 °C MAX
Net weight:	115 kg

Shipping weight:

392095 (Z9FREH2HF0)	105 kg
392179 (Z9FREH2HFN)	130 kg

Shipping height:

392095 (Z9FREH2HF0)	1080 mm
392179 (Z9FREH2HFN)	1120 mm

Shipping width:

1020 mm

Shipping depth:

860 mm

Shipping volume:

392095 (Z9FREH2HF0)	0.95 m ³
392179 (Z9FREH2HFN)	0.98 m ³

If appliance is set up or next to or against temperature sensitive furniture or similar, a safety gap of approximately 150 mm should be maintained or some form of heat insulation fitted.