

Service Trolleys Heated Banquet Trolley - 10x2/1 GN

ITEM # _____

MODEL # _____

NAME # _____

SIS # _____

AIA # _____

Main Features

- Temperature set-up from +30°C to +90°C, monitored through the digital display, allows to adjust temperature to the specific requirements of the hot dishes.
- Trolley reaches set temperature of 90°C in approximately 35 minutes.
- Heating via dry heat or moisturized air heating, which prevents food from drying out.
- Capable of holding GN 2/1 and GN 1/1 containers or plates on grids (grids included).
- Ergonomic handles to facilitate handling.
- Complies with main international certification bodies and is CE marked.

Construction

- Constructed in double-walled 304 AISI stainless steel with insulated panels.
- Thick, all-round perimetral bumpers on sides, doors and handles to improve shock absorption.
- Two fixed and two swivelling castors with brakes, all 125 mm in diameter.
- Equipped with spiral cable.

Optional Accessories

- Pair of AISI 304 stainless steel grids, GN 2/1 PNC 922175

351156 (BT1021H)

Heated banquet trolley
-10x2/1GN

Short Form Specification

Item No. _____

Constructed in double-walled, 304 AISI stainless steel with expanded polyurethane insulated panels. Ergonomic handles for easy movement. Temperature can be set from 30°C to 90°C with digital display. Humidity can be added inside the chamber to keep food from drying. N. 2 fixed castors and N. 2 swivelling castors with brakes, mm125 in diameter. Full perimeter bumpers for added shock protection. By using the optional eutectic plates it is possible to keep dishes at a temperature of +5°C for about two hours. Load capacity: 170 Kg.

APPROVAL: _____

Front

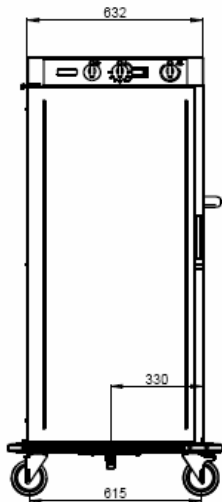

Side

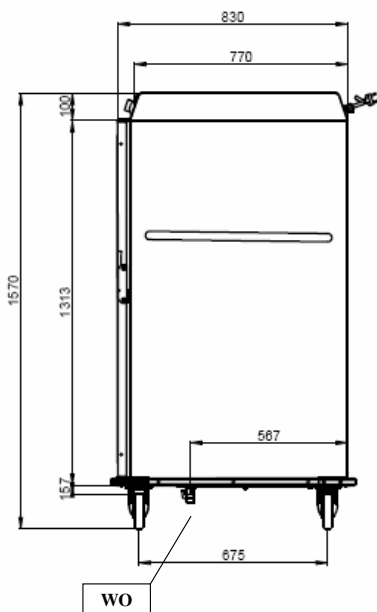

D = Drain
EI = Electrical inlet (power)

Top

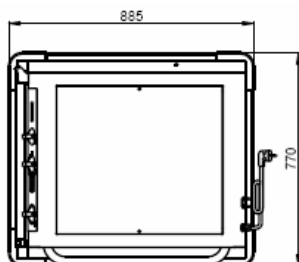

Electric

Supply voltage:
351156 (BT1021H) 230 V/1N ph/50/60 Hz
Total Watts: 2.7 kW

Key Information:

GN 2/1 containers - 100 10
GN 1/1 containers - 100 20
Load capacity 170 kg
External dimensions, Width: 770 mm
External dimensions, Depth: 885 mm
External dimensions, Height: 1570 mm
Net weight: 118 kg